

Light Duty Commercial Ultra Low NOx Power Direct Vent Gas Water Heater



Photo is of
UPDX-65S-55FR-3N

FEATURING:



The Light Duty UPDX Eco-Defender Safety System Models Feature:

- **Bradford White ICON System**[™]—Intelligent gas control with spark to pilot ignition system eliminates the constant burning pilot. This results in savings of pilot gas during stand by periods (120 V.A.C.).
 - **Enhanced Performance**—Proprietary algorithms provide enhanced First Hour Delivery ratings and tighter temperature differentials.
 - **Advanced Temperature Control System**—Microprocessor constantly monitors and controls burner operation to maintain consistent and accurate water temperature levels.
 - **Intelligent Diagnostics**—An exclusive green LED light prompts the installer during start-up and provides ten different diagnostic codes to assist in troubleshooting.
 - **Separate Immersed Thermowell**—High strength advanced polymer composite thermowell provides isolation between electric temperature sensor and surrounding water. No need to drain the tank when removing gas valve.
- **Ultra Low NOx Burner with Primary and Secondary Air Distribution Devices**—Ensures proper air to gas ratio for reduction of NOx generated by the combustion process.
- **Closed Combustion Venting System**—Power Direct Vent closed combustion system utilizes external air for combustion and exhausts directly to the outside through a separate two-pipe system. The air intake and exhaust vent are 3" connections. The equivalent feet of intake venting cannot be greater than the equivalent feet of exhaust venting.
- **Cast Aluminum Air Intake Boot**—A cast molded air intake boot design provides exceptional durability during installation and operation.
- **Flammable Vapor Sensor**—Electronic sensor prevents water heater operation if flammable vapors are detected.
- **Factory Installed Hydrojet[®] Total Performance System**—Cold water inlet sediment reducing device helps prevent sediment build up in tank. Increases first hour delivery of hot water while minimizing temperature build up in tank.
- **Vitraglas[®] Lining**—Bradford White tanks are lined with an exclusively engineered enamel formula that provides superior tank protection from the highly corrosive effects of hot water. This formula (Vitraglas[®]) is fused to the steel surface by firing at a temperature of over 1600°F (871°C).
- **More Precise Temperature Control**—With an adjustable temperature up to 180°F. (Not recommended for 180°F sanitization.)
- **Powerful Blower Motor**—Our design has higher torque for greater resistance to outside winds and the power to eliminate problems with difficult venting situations. This significantly quieter motor runs cooler for a considerably longer operational life.
- **Optional Concentric Vent Kit Termination**—3" termination fitting provides for only one exit opening through a wall or roof. (Subtract 10ft. for intake pipe and 10ft. for exhaust pipe when calculating total vent length.)
- **Horizontal and Vertical Venting**—With 3" or 4" PVC, ABS, or CPVC (Maximum equivalent vent length for each pipe on reverse side).
- **Side Connections**—3/4" NPT tapings allow easy connections for space heating applications (Potable water only).
- **2" Non-CFC Foam Insulation**—Covers the sides and top of tank, reducing the amount of heat loss. This results in less energy consumption, improved operation efficiencies and jacket rigidity.
- **Water Connections**—3/4" NPT factory installed true dielectric fittings extend water heater life and eases installation.
- **Factory Installed Heat Traps**—Design incorporates a flexible disk that reduces heat loss in piping and eliminates the potential for noise generation.
- **Protective Magnesium Anode Rod**—Provides added protection against corrosion for long trouble-free service.
- **Stainless Steel Flue Baffle**—Maximizes the amount of heat absorbed by the tank and reduces heat loss during standby periods.
- **Steel Tank**—Heavy gauge steel automatically formed, rolled and welded.
- **T&P Relief Valve**—Included.
- **Low Restriction Brass Drain Valve**—Durable tamper proof design..
- **Design Certified by CSA International (formerly AGA and CGA).**
- **Complies with the latest ultra-low NOx requirement (10 ng/J NOx limit).**

3 or 5-Year Limited Tank Warranties / 1-Year Limited Warranty on Component Parts.

For more information on warranty, please visit www.bradfordwhite.com

For products installed in USA, Canada and Puerto Rico. Some states do not allow limitations on warranties.

See complete copy of the warranty included with the heater.

Commercial Power Direct Vent Gas Water Heater

Light Duty Energy Saver Models

NATURAL GAS

Meet or exceed ASHRAE 90.1b (current standard) C.E.C. Listed
79% Recovery Efficiency

Model Number	Capacity		First Hour Rating** Gal.	Recovery at 100°F Rise*		A	B	C	D	E	F	G	H	J	K	L	Approx. Shipping Weight lbs.	
	U.S. Gal.	Imp. Gal.		Nat. U.S. GPH	Nat. Imp. GPH	Floor to Exhaust Outlet in.	Jacket Dia. in.	Vent Size in.	Floor to T&P Conn. in.	Floor to Gas Conn. in.	Floor to Space Heating Return in.	Floor to Space Heating Supply in.	Floor to Air Intake in.	Floor to Water Conn. in.	Depth in.	Ct. Line Distance From Intake to Exhaust in.		
U-PDX-50S-50FR-3N	48	40	50,000	92	48	40	68	22	3	52 ¹ / ₄	13 ⁵ / ₈	15 ³ / ₄	52 ¹ / ₄	67	59 ³ / ₄	32	9 ¹ / ₄	303
U-PDX-65S-55FR-3N	65	54	55,000	106	53	44	71 ¹ / ₄	24	3	55 ⁵ / ₈	13 ⁵ / ₈	15 ³ / ₄	55 ⁵ / ₈	69 ¹ / ₂	63	34 ¹ / ₈	9 ¹ / ₄	330
U-PDX-75S-55FR-3N	75	62	55,000	122	53	44	71	26	3	54 ¹ / ₄	16 ¹ / ₄	19	54 ¹ / ₄	69 ³ / ₈	62 ³ / ₄	36	11 ¹¹ / ₁₆	375

Model Number	Capacity		First Hour Rating** Liters	Recovery at 56°C Rise*		A	B	C	D	E	F	G	H	J	K	L	Approx. Shipping Weight kg.
	Liters	kW Input		Nat. kW Input	Nat. Liters/Hour	Floor to Exhaust Outlet mm.	Jacket Dia. mm.	Vent Size mm.	Floor to T&P Conn. mm.	Floor to Gas Conn. mm.	Floor to Space Heating Return mm.	Floor to Space Heating Supply mm.	Floor to Air Intake mm.	Floor to Water Conn. mm.	Depth mm.	Ct. Line Distance From Intake to Exhaust mm.	
U-PDX-50S-50FR-3N	182	14.7	348	182	1727	559	76	1327	346	400	1327	1701	1517	812	235	137	
U-PDX-65S-55FR-3N	246	16.2	401	201	1809	610	76	1489	346	400	1489	1765	1600	867	235	149	
U-PDX-75S-55FR-3N	284	16.2	462	201	1803	660	76	1378	413	483	1378	1762	1594	914	297	170	

Available in Natural Gas only.

For 5 year model, change suffix "3" to "5".

*Based on manufacturers rated recovery efficiency.

**First Hour Rating is based on the latest AHRI Directory Listings.

110 V.A.C Required for Power Venting / 110 V.A.C., 60HZ, 3.1 Amperes.

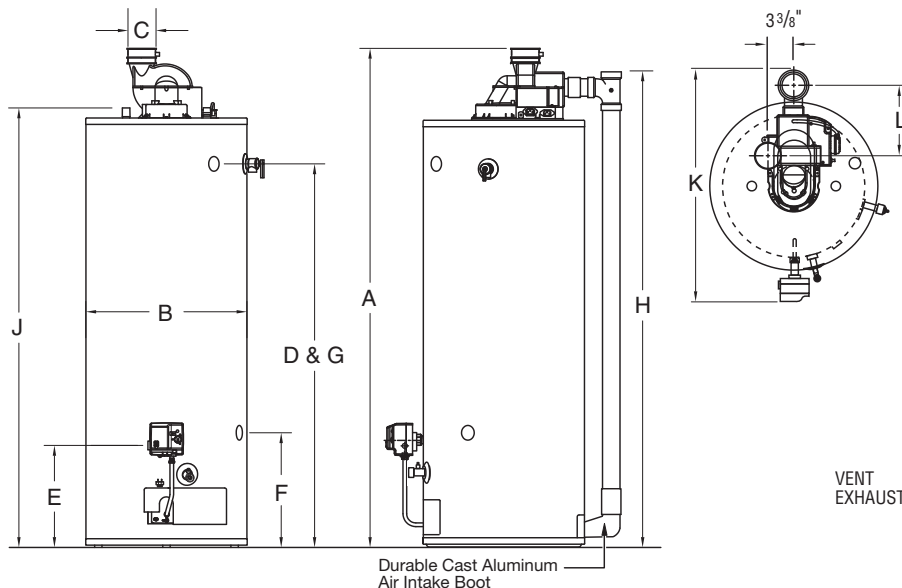

3" Vent Pipe	PDX-50S PDX-65S	PDX-75S
Max. Intake Length	60 ft.	50ft.
Max. Exhaust Length	60 ft.	50ft.
Min. Vent Length	7 ft.	7ft.
Number of 90° Elbows	1 55 ft. 2 50 ft. 3 45 ft.	45ft. 40ft. 35ft.

4" Vent Pipe	PDX-50S PDX-65S	PDX-75S
Max. Intake Length	100 ft.	90ft.
Max. Exhaust Length	100 ft.	90ft.
Min. Vent Length	7 ft.	7ft.
Number of 90° Elbows	1 95 ft. 2 90 ft. 3 85 ft.	85ft. 80ft. 75ft.

Subtract 5ft. for each additional 90° elbow.

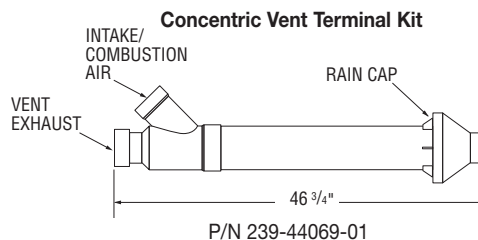

Meets NAECA Requirements

General

All gas water heaters are certified at 300 PSI test pressure (2068 kPa) and 150 PSI working pressure (1034 kPa). All water connections are 3/4" NPT (19mm) on 11" (203mm) centers. All gas connections are 1/2" (13mm).

All models design certified by CSA International (formerly AGA/CGA), to meet ANSI standard Z-21.10.1 and peak performance rated.

Dimensions and specifications subject to change without notice in accordance with our policy of continuous product improvement.

Suitable for Water (Potable) Heating and Space Heating.

Toxic chemicals, such as those used for boiler treatment, shall NEVER be introduced into this system. This unit may NEVER be connected to any existing heating system or component(s) previously used with a non-potable water heating appliance.



For U.S. and Canada field service, contact your professional installer or local Bradford White sales representative.

Sales 800-523-2931 • Fax 215-641-1670 / Technical Support 800-334-3393 • Fax 269-795-1089 • Warranty 800-531-2111 • Fax 269-795-1089

International: Telephone 215-641-9400 • Telefax 215-641-9750 / www.bradfordwhite.com

BRADFORD WHITE-CANADA INC. Sales / Technical Support 866-690-0961 / 905-238-0100 • Fax 905-238-0105 / www.bradfordwhite.com

Built to be the Best™

©2013, Bradford White Corporation. All rights reserved.